



Rechargeable 2-in-1 Vacuum Cleaner



Model Number HS-2H1-001

INSTRUCTION MANUAL

IM Version No: V1.1

Issue Date: 12 June 2015

AFTER SALES SUPPORT

  1300 886 649

 info@tempo.org

MODEL: HS-2H1-001 PRODUCT CODE: 51024 09/2015



N13275

Welcome

Congratulations on choosing to buy a Stirling® product.

All products brought to you by Stirling® are manufactured to the highest standards of performance and safety and, as part of our philosophy of customer service and satisfaction, are backed by our comprehensive 3 Year Warranty. We hope you will enjoy using your purchase for many years to come.

Contents

- 02 Welcome**
- 04 Warranty Details**
- 05 General Safety Instructions**
- 08 Product Overview**
- 10 Getting Started**
- 12 Instructions**
- 13 FAQs and Troubleshooting Guide**
- 14 Other Useful Information**
- 19 Repair and Refurbished Goods or Parts Notice**



STIRLING[®]

Rechargeable 2-in-1 Vacuum Cleaner

Warranty Details

The product is guaranteed to be free from defects in workmanship and parts for a period of 36 months from the date of purchase. Defects that occur within this warranty period, under normal use and care, will be repaired, replaced or refunded at our discretion, solely at our option with no charge for parts and labour. The benefits conferred by this warranty are in addition to all rights and remedies in respect of the product that the consumer has under the Competition and Consumer Act 2010 and similar state and territory laws.

Our goods come with guarantees that cannot be excluded under the Australian Consumer Law. You are entitled to a replacement or refund for a major failure and to compensation for any other reasonably foreseeable loss or damage. You are also entitled to have the goods repaired or replaced if the goods fail to be of acceptable quality and the failure does not amount to a major failure.



General Safety Instructions

IMPORTANT SAFETY INSTRUCTIONS

READ CAREFULLY AND KEEP FOR FUTURE REFERENCE

Read this manual thoroughly before first use, even if you are familiar with this type of product. The safety precautions enclosed herein reduce the risk of fire, electric shock and injury when correctly adhered to. **Keep the manual in a safe place for future reference**, along with the completed warranty card, purchase receipt and carton. If applicable, pass these instructions on to the next owner of the appliance. **Always follow basic safety precautions and accident prevention measures when using an electrical appliance, including the following:**

Usage conditions and restrictions

- **Domestic use only:** This appliance is intended for indoor household use only. It is not suitable for commercial or industrial use. Do not use it outdoors or on wet surfaces.
- **Intended purpose:** This appliance has been designed exclusively for vacuum cleaning dry carpeted surfaces (except shag pile carpets), robust hard floors and dry residues. Do not use it for anything other than its intended purpose, and only use it as described in this manual.
- **Accessories:** Only use the device with the accessories supplied.
- **Improper use:** Improper assembly and use of accessories that are not recommended in this manual may result in the risk of fire, electric shock and/or injury to persons. We assume no liability for any eventual damage caused by improper use or faulty handling.
- **Damage:** Check the appliance and connections regularly for visible damage. Do not use it if the housing or any other part is damaged. A damaged cord must be replaced by the manufacturer, an authorised service centre or similarly qualified personnel in order to avoid a hazard. **In case of damage, contact our after sales support line to arrange return or repair of the product.**
- **Usage restriction:** This appliance may be used by children aged 8 years and above and by persons with limited physical, sensory or mental capabilities or lack of experience and knowledge, provided that they are under supervision or have been told how to use the appliance safely and are aware of the potential risks. Children must not use the appliance as a plaything. Cleaning and user maintenance tasks may not be carried out by children unless they are supervised.
- **Prevent injury:** Keep hair, loose clothing, fingers and all parts of the body away from openings and moving parts. Do not use the vacuum cleaner on people or animals, or point it at them. Take extra care when vacuuming on stairs.

General Safety Instructions (Cont.)

- **Prevent blockage:** Always make certain that the ventilation slots are not obstructed, keep all openings free of dust, lint, hair or anything that may reduce the airflow. A blocked ventilation circuit can result in overheating and damage to the appliance. Do not use the product with any openings blocked.
- **WARNING: Risk of injury! Do not use the vacuum cleaner to pick up:**
 - Flammable or combustible fluids (such as fuel or solvent), burning substances (such as ash, cigarettes or hot coals) or use it in the presence of explosive liquids or fumes
 - Hard or sharp objects such as shards of glass, nails, coins
 - Harmful or toxic materials (such as chlorine bleach, ammonia, drain cleaner, stone dust, gypsum, cement or similar substances)
 - Water or other liquids, or vacuum in areas where liquids may be present.
- **Protect from heat:** Keep the product away from heating elements, ovens or other heated appliances and surfaces.
- **Filter:** Do not use the appliance without the dust filter inserted.
- **Storage:** Store the appliance in a cool, dry indoor area, disconnected from the power supply and out of children's reach.
- **Service and repair:** The appliance has no user-serviceable parts contained within. Do not attempt to open, disassemble or repair the device or the battery charger yourself, or to replace the power cord. Only have it repaired by an authorised technician, or contact the after sales support line for advice.
- **Rechargeable battery hazards:** This product contains rechargeable batteries. Do not throw the appliance into a fire and do not subject it to high temperatures. There is a risk of explosion!
Under extreme conditions, leaks in the battery cells may occur. In the event that battery fluid comes into contact with skin or eyes, immediately rinse the affected area with water. Contact a physician.

Electrical safety (charging)

- **Mains adaptor/battery charger:** Only use the original mains adaptor/battery charger supplied with this appliance to charge it. Do not change the appliance with a different adaptor. Do not use the supplied charger for charging a different appliance.
- **Voltage:** Before connecting the battery charger to the cradle and the power supply, ensure that the electrical voltage and circuit frequency correspond to those indicated on the charger rating label.
- **No extension cord:** Do not use the mains adapter/battery charger with an extension cord; connect it directly to a power socket.

General Safety Instructions (Cont.)

- **Connection/disconnection:** To connect the battery charger, insert the plug firmly into an appropriate mains socket. To disconnect, grip the power plug firmly and remove it from the outlet, do not pull on the cord.
- **Charging:** When charging the appliance, place the cradle:
 - On a flat surface to avoid overturning
 - Close to a power point so no one trips over the cord
 - Away from heated surfaces, such as a stove or heater surface.
- **No outdoor use:** Do not use or charge the appliance outdoors.
- **Protect the power cord:** Do not kink or damage the battery charger's power supply cord. If it is damaged, contact our after sales support line for advice.
- **Protect from moisture:** To protect against electric shock, do not immerse the cord, plug or charger in water. Ensure your hands are dry before use.
- **Unattended:** Do not leave the appliance unsupervised while it is charging.
- **Cleaning and storage:** Before cleaning, servicing or moving the vacuum cleaner, make sure the battery charger is disconnected from the appliance and from the power socket.

Product Overview

Scope of delivery

Handheld unit

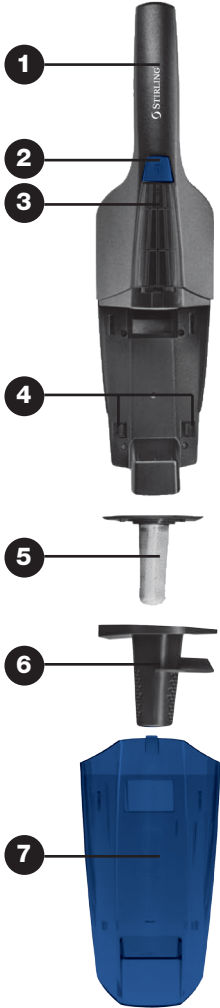

Upright unit



Accessories

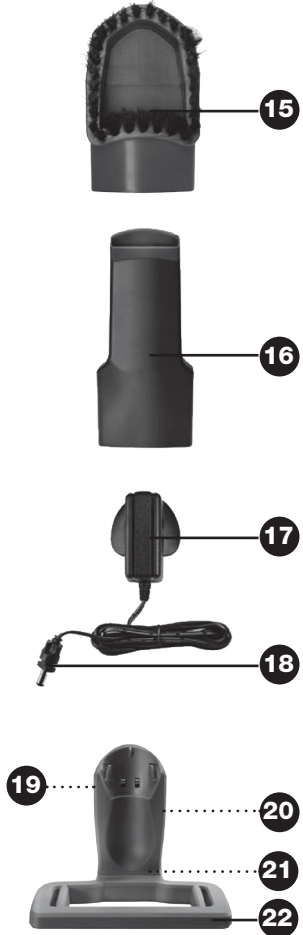

Product Overview (Cont.)

Parts list

A Handheld unit

- 1 Grip/handle
- 2 On/Off switch
- 3 Charge indicator light
- 4 Dust container release buttons
- 5 Dust filter
- 6 Coarse filter
- 7 Dust container

B Upright unit

- 8 Grip/handle
- 9 On/Off switch
- 10 Handle release latch (at the back)
- 11 Handheld unit release button (at the back)
- 12 Handheld unit recess
- 13 Floor head with rotary brush
- 14 LED lamps

C Accessories

- 15 Brush attachment
- 16 Crevice nozzle
- 17 Battery charger/mains adaptor
- 18 DC connector
- 19 Holder for brush nozzle (at the back)
- 20 Holder for crevice tool (at the back)
- 21 Charging socket (at the back)
- 22 Cradle/stand

D Documentation (not shown)

Instruction manual
Quick start guide
Warranty certificate

Getting Started

Before first use

- This product has been packaged to protect it against transportation damage. Unpack it and keep the original carton and materials in a safe place. It will help prevent any damage if the product needs to be transported in the future, and you can use it to store the appliance when it is not in use. In the event it is to be disposed of, please recycle all packaging materials where possible.
- Plastic wrapping can be a suffocation hazard for babies and young children, so ensure all packaging materials are out of their reach and disposed of safely
- Unwind the cord of the battery charger to its full length and inspect it for damage. Do not use the charger if the cord is damaged. **In case of damage, contact our after sales support line for advice on examination, repair or return of the damaged product.**
- Read this manual to familiarise yourself with all the parts and operating principles of the appliance. Pay particular attention to the safety instructions.
- Make sure all parts listed on page 9 are inside the box. If anything is missing, contact our after sales support line.

CHARGING TIME

- Before first use, the in-built battery needs to be charged according to the instructions on the opposite page. During charging, the charge indicator light at the front of the handheld unit illuminates red. When the appliance is fully charged, the it will illuminate green.
- After subsequent use, recharge the appliance when the suction power decreases noticeably.
- In order to ensure that it is always ready for use, we recommend you leave the appliance on the cradle when not in use, connected to the mains adaptor.

Getting Started (Cont.)

Assembly and disassembly

Your new Rechargeable 2-in-1 Vacuum Cleaner can be used as a handheld unit or as an upright vacuum cleaner with the handheld unit assembled into the frame.

- **To connect the handheld unit into the frame for use as an upright vacuum**, insert the tip of the handheld unit into the opening in the handheld unit recess. Then press the grip of the handheld unit into the handle until it clicks securely into position (Fig. 1).
- **To remove the handheld unit from the frame for use as a handheld unit**, press the handheld unit release button at the back of the frame. Then pull the handheld unit up and out of its recess in the frame (Fig. 2).
- **To fold down the handle for convenient storage**, press the handle release latch at the back of the frame and fold down the handle.

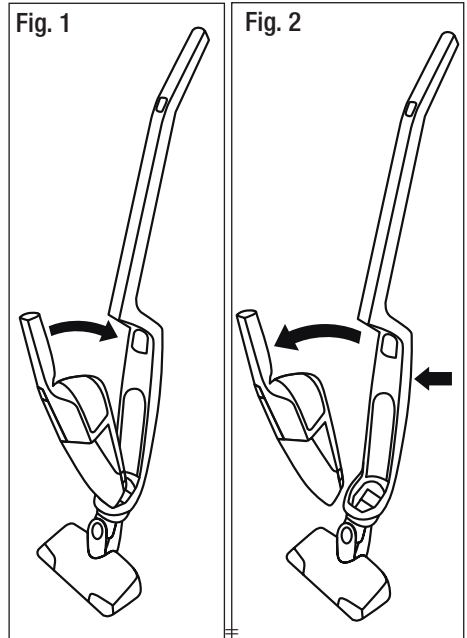

Charging the appliance

CAUTION!

Ensure the appliance is switched off before starting to charge the batteries.

- Connect the battery charger to a mains socket and insert the DC connector into the charging socket at the underside of the cradle/stand. Feed the cable through the cable channel on the charging socket so that the cradle is not resting on the cable.
- Position the cradle/stand close to a mains socket, well away from heat sources and excessive moisture.
- Place the complete vacuum cleaner (frame with the handheld unit attached) onto the cradle. The charge indicator light at the front of the handheld unit illuminates red. When the appliance is fully charged, the light will illuminate green.

Instructions

Upright vacuuming

The handheld unit fits securely into the frame of the vacuum cleaner. Before you use the vacuum cleaner in an upright position to vacuum floors, make sure the handheld unit is properly fitted into the frame and the unit is sufficiently charged (see page 11).

- Attach the handheld unit into the frame as described on the previous page. If the handle is folded down, press the handle release latch at the back of the frame and pull up the handle.
- Start the vacuum cleaner by pressing the On/Off switch on the upper handle. The two LED lamps at the front of the floor brush will illuminate and the rotary brush will start turning.
- Guide the floor brush over the area to be vacuumed. Hold the grip so that the floor brush moves smoothly over the floor.
- Press the On/Off switch when you have finished vacuuming. The rotary brush will stop and the LED lamps go out.

Handheld vacuuming

The handheld unit is designed for convenient vacuuming of furniture, stairs, the car interior or any areas that are more difficult to access with an upright vacuum cleaner. Before you use the handheld vacuum cleaner, make sure the unit is sufficiently charged (see page 11).

- Remove the handheld unit from the frame as described on the previous page.
- If required, attach the crevice nozzle or the brush attachment to the opening at the front of the handheld unit.
- Start the vacuum cleaner by pressing the On/Off switch.
- When you have finished vacuuming, press the On/Off switch again.

IMPORTANT!

- **Blockages:** Make sure the suction opening is always open and unblocked. Blockages lead to overheating and damage to the motor.
- **Shag pile carpet:** Do not vacuum shag pile carpet with the floor brush. The rotary brush can get caught in the carpet and block.
- **Parquetry:** Before upright vacuuming highly polished parquetry surfaces, test the appliance on an inconspicuous area to ensure suitability.
- **Filters:** Ensure both the dust and coarse filters are in place before vacuuming.
- **Recharging:** As soon as the suction power of the appliance begins to diminish noticeably, connect the appliance to the charger.

FAQs and Troubleshooting Guide

WARNING!

Always unplug the vacuum cleaner before any maintenance checks.

If you experience problems with your Rechargeable 2-in-1 Vacuum Cleaner, check in the table below for solutions to common problems. If our suggestions do not help you with the problem, or if you experience any other problems with the appliance, do not try and manage them by yourself. Contact our after sales support line for advice on repair or replacement.

Problem	Possible cause	Solution
The appliance is not working.	The battery is not charged.	Connect the appliance to the battery charger.
	The appliance is defective.	Contact our after sales support centre for advice.
The appliance is running but hardly sucking up any dirt.	The battery is not sufficiently charged.	Connect the appliance to the charger until the battery is fully charged.
	The dirt container is full.	Empty the dirt container.
	The dust filter is blocked.	Clean the dust filter.
The appliance will not charge.	The charger is not correctly connected to the socket/mains plug.	Check the connections of the charger and ensure it is properly connected to the cradle/stand and the wall outlet.
	The charger is defective.	Contact our after sales support centre for advice.

Other Useful Information

Cleaning and care

WARNING!

- Always disconnect the charger from the mains socket and remove the DC connector from the charging socket on the cradle before cleaning the cradle.
- Always remove the handheld unit from the vacuum cleaner frame before cleaning the handheld unit, the frame or the floor brush.
- Do not use abrasive or aggressive cleaning materials. These could damage the surface of the appliance.

To keep the vacuum cleaner in good working order, and to achieve the best results when vacuuming, we recommend you empty the dirt container and clean the dust filter after every use.

Emptying the dirt container and cleaning the filters

- Press the handheld unit release button at the back of the frame and pull the handheld unit up and out of the frame.
- Press both dust container release buttons simultaneously and pull the dust container up and out of its recess.
- Pull out the dust filter with your fingers. Shake out loose dirt particles. If necessary, rinse the filter in clear water and let it air dry. Do not use hot air to dry the dust filter.
- Then remove the coarse filter, also by simply pulling it out. Shake out loose dirt particles and wipe it clean with a dry or damp cloth.
- Empty the dirt container and wipe it clean with a dry or damp cloth.

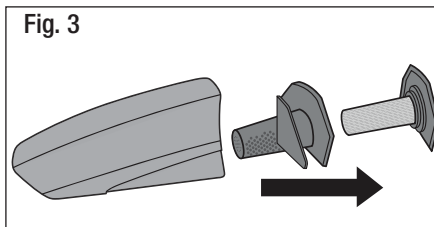

- When all parts are completely dry, reassemble the appliance. First insert the coarse filter, then the dust filter into the dust container. Then replace the dust container by first inserting the catch into the notch in the handheld unit and then pushing the front part of the dust container firmly downwards until it clicks securely into place.

Other Useful Information (Cont.)

Cleaning the appliance and attachments

If the appliance needs cleaning, wipe it with a damp cloth. Add a mild detergent to the cloth, if required to remove stubborn dirt. Ensure that the appliance is completely dry before the next use.

If the tools require cleaning, use a slightly damp cloth and/or a small brush (such as an old toothbrush) to clean the crevice nozzle and brush attachment.

Cleaning the rotary brush

The rotary brush is located at the underside of the floor brush. Larger dirt and dust residues, hair and threads can become caught in the brush, which can block or jam the suction mechanism and affect dirt removal. It is therefore important that you regularly check the state of the brush and clean it when required.

- Turn the floor brush upside down.
- Push the catch on the cover plate to the rear so that you can remove the cover plate (Fig. 4).
- Lift out the rotary brush and clean it.
- To replace the rotary brush, first push the broad end onto the drive shaft so that the rotary brush hooks into place.
- Then push the other end into the mount so that the rotary brush sits straight in the floor brush.
- Replace the cover plate and fasten it firmly into place.

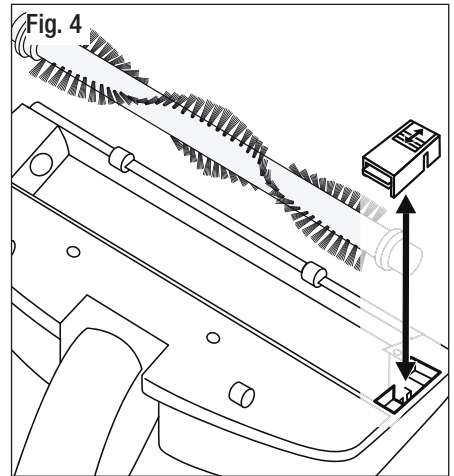

NOTE: The LED lamps are maintenance-free and cannot be changed.

Storage

- **Storage environment:** Store the appliance in a dust-free and dry location, out of children's reach. Storing it in its original carton will protect it from dust.
- **For convenient upright storage,** store the appliance, fully assembled, on the cradle/stand. We recommend you leave the battery charger connected to the cradle/stand and a power point so the unit can recharge when not in use.
- You can store the crevice tool and brush nozzle at the back of the cradle/stand in their respective holders.
- **For compact storage,** fold down the handle, as described on page 11.

Other Useful Information (Cont.)

Service, repair and spare parts

If the appliance is damaged, **do not attempt to repair it yourself**. Contact our after sales support centre to arrange for examination or repair of the product.

The following spare parts are available for purchase from our after sales support centre. To purchase a spare part, call the centre on **1300 886 649** or email us at **info@tempo.org**

- Battery charger/mains adaptor
- Brush nozzle
- Coarse filter and cover
- Cradle/stand
- Crevice tool
- Dust container
- Dust filter and cover
- Handheld vacuum cleaner
- Power cord
- Rotating brush

Technical specifications

Adaptor input voltage	AC 100–240V
Adaptor output voltage	13.5V DC, 500mA
Battery working voltage	10.8V DC
Rated power	75W
Battery specification	Li-ion 10.8V 1800mAh
Dimensions (mm)	1140 (H) x 273 (W) x 190 (D)
Weight	2.3kg

Compliance

This product complies with the following standards:

- **Electrical safety** 60335.1:2011+A1:2012 and 60335.2.2:2010+A1:2011+A2:2014
- **Electromagnetic compatibility:** EN 55014:2006+A1:2009+A2:2011

Other Useful Information (Cont.)

Responsible disposal

- This product contains rechargeable batteries. Do not throw the appliance into a fire and do not subject it to high temperatures. There is a risk of explosion!
- At the end of its working life, do not throw this appliance out with your household rubbish. Electrical and electronic products contain substances that can have a detrimental effect on the environment and human health if disposed of inappropriately. Observe any local regulations regarding the disposal of electrical consumer goods and dispose of it appropriately for recycling. Contact your local authorities for advice on recycling facilities in your area.



STIRLING[®]

Rechargeable 2-in-1 Vacuum Cleaner

Repair and Refurbished Goods or Parts Notice

Unfortunately, from time to time, faulty products are manufactured which need to be returned to the supplier for repair.

Please be aware that if your product is capable of retaining user-generated data (such as files stored on a computer hard drive, telephone numbers stored on a mobile telephone, songs stored on a portable media player, games saved on a games console or files stored on a USB memory stick) during the process of repair, some or all of your stored data may be lost. **We recommend you save this data elsewhere prior to sending the product for repair.**

You should also be aware that rather than repairing goods, we may replace them with refurbished goods of the same type or use refurbished parts in the repair process.

Please be assured though, refurbished parts or replacements are only used where they meet ALDI's stringent quality specifications.

If at any time you feel your repair is being handled unsatisfactorily, you may escalate your complaint. Please telephone us on 1300 886 649 or write to us at:

Tempo (Aust) Pty Ltd ABN 70 106 100 252
PO BOX 6056 Frenchs Forest, Sydney, Australia NSW 2086
Telephone: 1300 886 649 (Aust) - Fax: (02) 9975 2688
Tempo Help Desk: 1300 886 649 (Aust)
(Operating Hours: Mon-Fri 08:30am to 06:00pm EST)
Email: info@tempo.org



Read the manual.
It will help you get the best out of your product.

Still have questions?
Call After Sales Support
1300 886 649
Or visit www.tempo.org

Warranty returns

Should you for any reason need to return this product for a warranty claim, make sure to include all accessories with the product.

Product does not work?

If you encounter problems with this product, or if it fails to perform to your expectations, make sure to contact our After Sales Support Centre on 1300 886 649 before returning it to the store for a refund.

For an electronic copy of this manual, go to www.stirlingappliances.com.au and download a copy.

Instruction Manual Revision Index

Version No	Issue Date	Description
V1.0	05 June 2015	Original release
V1.1	12 June 2015	Minor updates